

SCREW: NONE	MATERIAL: COPPER	REV: D	 800-776-9775 www.ilSCO.com
CAT. NO.: SEE CHART	PLATING: EL-TIN	DRAWN BY:DW SCALE: NTS	
INFORMATION SHEET:FORM 157	MARKING: SEE CHART	DATE:6/3/2008 SIZE: B	
			DWG NO: Y0403-S-4
			SHEET: 1 OF 1

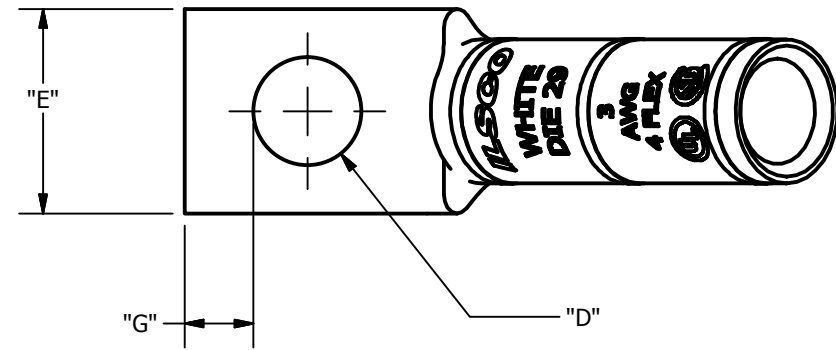

DETAIL C  
INK MARK TOP & BOTTOM

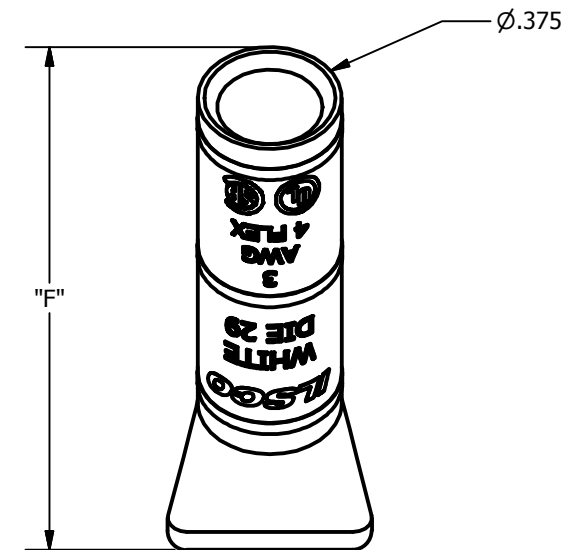
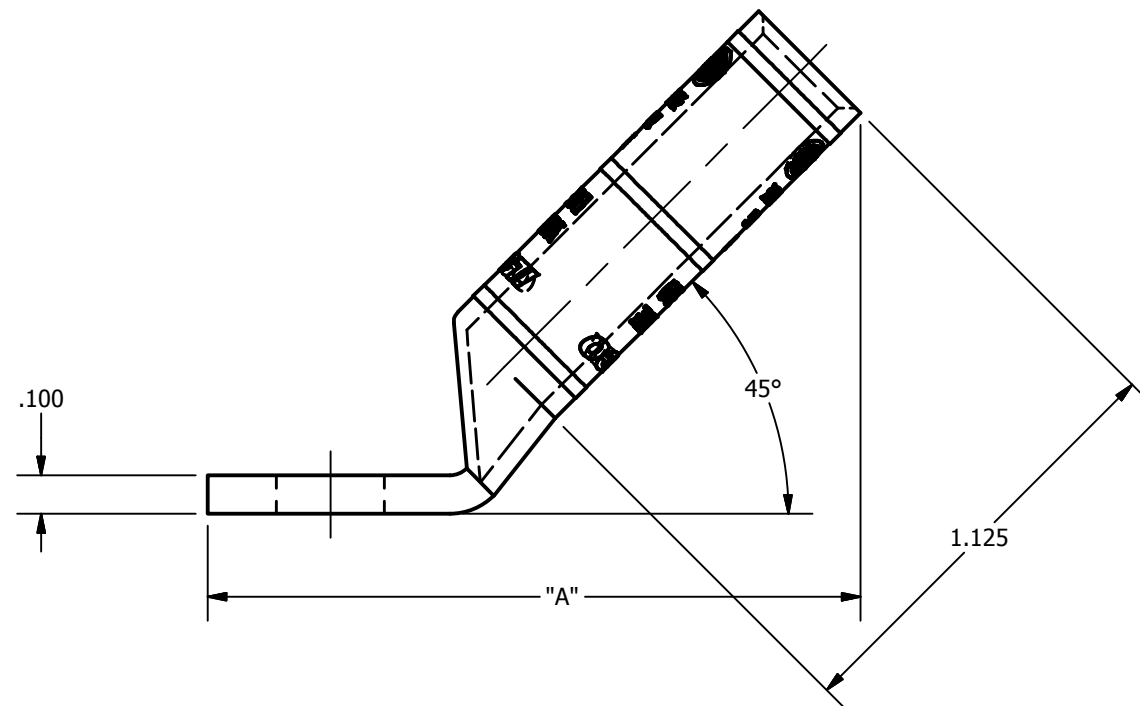

CATALOG NUMBER	"A"	"D"	"E"	"F"	"G"	TANG MARKING
CLNB-3-8-4	1.690	0.195	0.532	1.316	0.129	UL, ILSCO, CSA, CLNB-3-8-4, 8, 3 AWG, 4 FLEX, DIE 29
CLNB-3-10-4	1.690	0.219	0.532	1.316	0.148	UL, ILSCO, CSA, CLNB-3-10-4, 10, 3 AWG, 4 FLEX, DIE 29
CLNB-3-14-4	1.808	0.281	0.532	1.320	0.180	ILSCO, C-3-14, 3 AWG, 4 FLEX, DIE 29, UL, CSA
CLNB-3-12-4	2.378	0.562	0.750	1.320	0.265	UL, ILSCO, CSA, CLNB-3-12-4, 1/2, 3 AWG, 4 FLEX, DIE 29
CLNB-3-38-4	2.003	0.406	0.593	1.320	0.211	UL, ILSCO, CSA, CLNB-3-38-4, 3/8, 3 AWG, 4 FLEX, DIE 29
CLNB-3-516-4	2.003	0.343	0.532	1.320	0.180	UL, ILSCO, CSA, CLNB-3-516-4, 5/16, 3 AWG, 4 FLEX, DIE 29